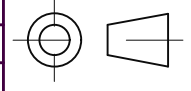

- NOTES
1. DIMENSIONAL TOLERANCE +/- 0.1mm
 2. Break ALL SHARP CORNERS 0.5MM AND DEBUR ALL HOLES
 3. CLEAN ALL THE WELDS FREE FROM WELD SPLATER
 4. SURFACE FINISH OF ALL SURFACES MINIMUM 6.3

1	1	PS0062002	6MM THICK GR316 STAINLESS STEEL	1.28
ITEM	QTY	PART No.	DESCRIPTION	Kg
		TC PROCESS EQUIPMENT COPYRIGHT THRIVE CONSULTING PTY LTD SYDNEY AUSTRALIA. NO PART OF THIS DRAWING MAYBE REPRODUCED WITHOUT PERMISSION		TITLE
		MBSX BELT SCALE STRINGER MOUNTING BRACKET		
DRAWN	MNH	21/04/2026	 DRG No. PS0062002	A4
CHECKED	RAS	23/01/2025		
ENG. MGR				
APPR'D	MAA	23/01/2025		
			SCALE 1:1	REVISION 0