

Compact mounts for ring torsion load cells model VCN

- Simple, trouble free installation of load cells
- Low head height
- Self centring elastomer mount
- Adjustable side hard stop
- Adjustable lift off protection
- Low profile design
- Earth strap

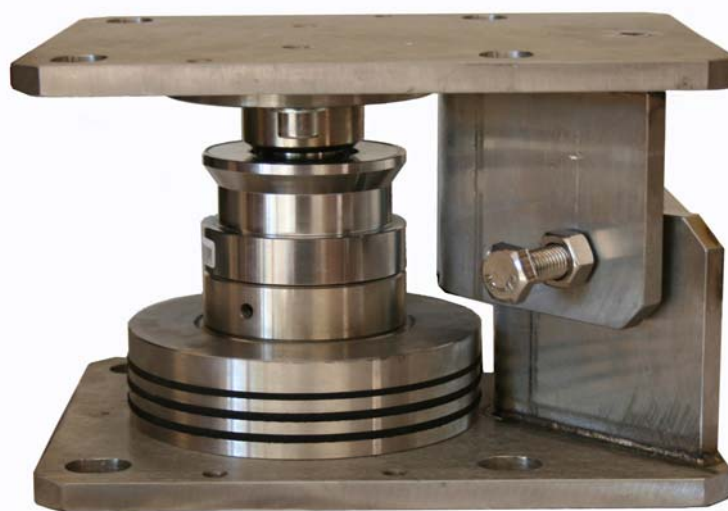

Application

The compact load cell mount is a self contained, low profile mount for RTC load cells. Designed to ease the installation requirements of load cells by including the all the hardware for correct load cell mounting in one compact, self-contained assembly.

Units should be installed to allow the weigh vessel to float on the self-centering mounts. The axis of horizontal restraint (back plate) should mirror around the weigh vessel to fully restrain against side movement and vertical lift.

Construction

The compact mount comprises the self-centring elastomeric mount. The self centring allows the weigh vessel to float on the load cells reducing errors from mechanical interface. The elastomer mount allows the structure slight horizontal movement (usually due to thermal expansion) while maintaining accurate weighing.

The unit features both a vertical (lift-off) and horizontal adjustable hard stop.

The mount is constructed from mild steel and zinc plated or optional Stainless Steel.

Features

- Low profile design.
- Simple trouble free application, removes the need for lift off and side restraints.
- Protects the load cells and ensures best possible accuracy.
- Integrated Earth strap.

Support Point Arrangement

Admissible loads per support point:

Maximum Horizontal force: 10 % x L_n

Maximum Vertical lift-off (tensile) force: 15 % x L_n

L_n = Rated load per support point

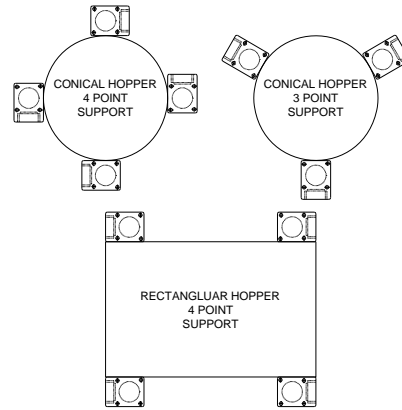

Dimensions

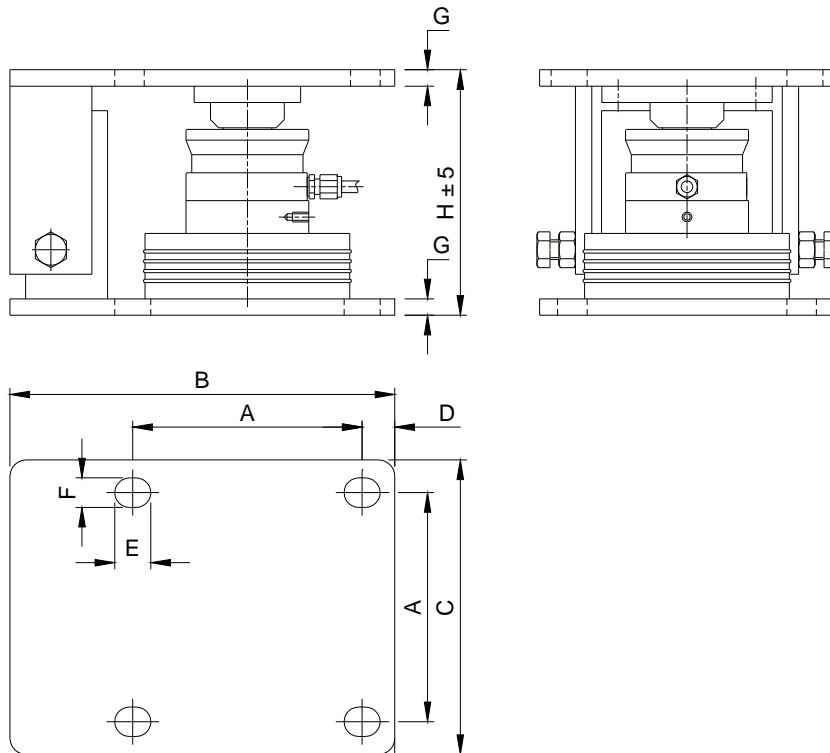

Model	VCN 10	VCN 15	VCN 22	VCN 33	VCN 47	VCN 68
Part No.	PS0003901	PS0003902	PS0003903	PS0003903	PS0003905	PS0003906
Dim A	140	140	140	200	230	230
Dim B	235	235	235	340	380	380
Dim C	180	180	180	250	280	280
Dim D	20	20	20	35	45	45
Dim E	22	22	22	26	30	30
Dim F	18	18	18	22	26	26
Dim G	10	10	10	12	20	20
Dim H	150	150	150	192	230	240
Wt. (inc. L/C)	19 kg	19 kg	19 kg	42 kg	65 kg	65 kg

Dimensions and specifications are subject to change without notice.

