

TECHNICAL DATA	
MINIMUM STRAIN	50 MICROSTRAIN
MAXIMUM STRAIN	1050 MICROSTRAIN (CONTINUOUS) 1500 MICROSTRAIN (SINGLE OPERATION)
SENSITIVITY	1.5mV/V AT 1000 MICROSTRAIN
TOTAL ERROR	0.1% OF STRAIN RANGE
TEMPERATURE EFFECT	0.005% OF ZERO & APPLIED LOAD
INPUT RESISTANCE	350 OHM
TEMPERATURE RANGE	-20° TO 80° C
EXCITATION VOLTAGE	RECOMMENDED 10V TO MAX. 15V
CONSTRUCTION	IP68 ABS PLOYPROPYLENE
FIXATION	M8 GRADE 12.9 SOCKET HD. CAP SCREW
CABLE LENGTH	3M X 4 CORE 10MM CONVOLUTE TUBING
CABLE COLOURS	RED            EXCITATION + BLUE        EXCITATION - GREEN       SIGNAL + YELLOW     SIGNAL -

COMPRESSION ALONG THIS  
AXIS IS POSITIVE

20mm X 20mm MOUNTING PAD 3 PLACES

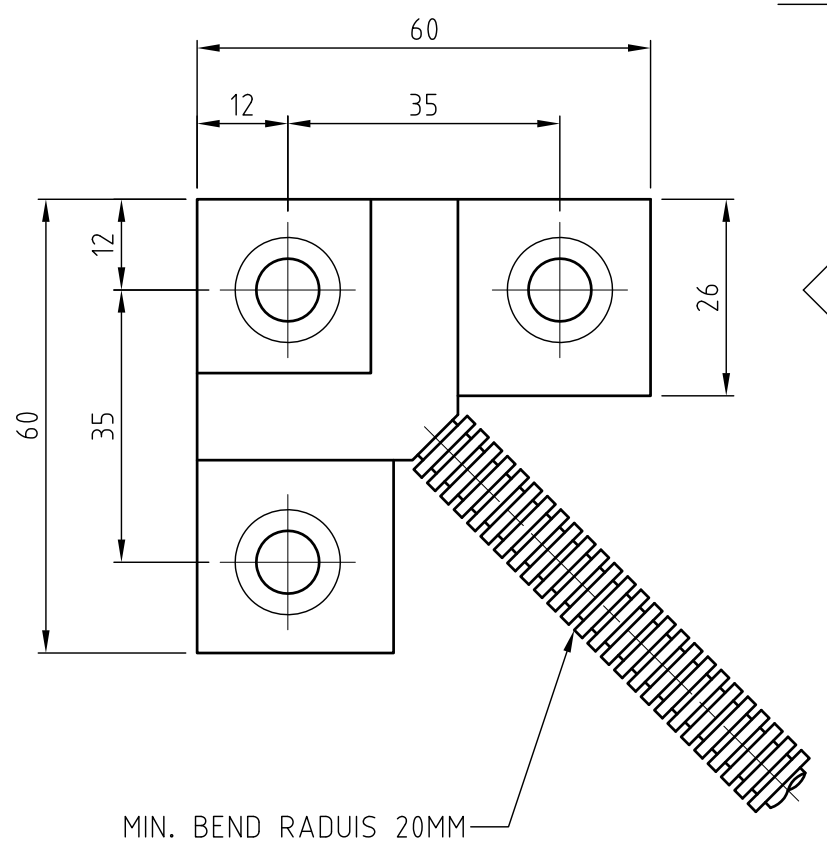
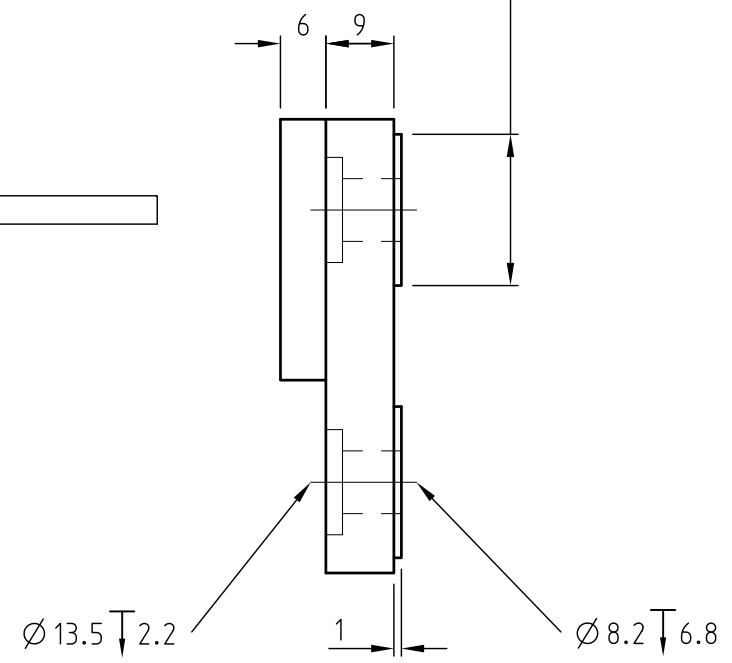

INSTALLATION

THE SENSORS MUST BE INSTALLED ON A FLAT SURFACE COMPLETELY COVERING THE MOUNTING PLATES. MINIMUM 60MM X 5THK. WITH MINIMUM CROSS SECTION AREA 500MM<sup>2</sup>.

THE MOUNTING SURFACE SHOULD BE CLEAN OF PAINT, GREASE, ETC AND THAT THE SURFACE BE CLEAN TO THE NAKED EYE AND THEN WIPED, IN A TWO STAGE CLEANING PROCESS, WITH LOCTITE 7063 OR 20162 DEGREASING AGENT. IT IS RECOMMENDED THAT THE SENSOR IS FIXED WITH AN ADHESIVE, FOR EXAMPLE LOCTITE RETAINING COMPOUND 638 OR EQUIVALENT.

THE SENSORS SHOULD BE FIRST LOOSELY BOLTED (WITH M8 GRADE 12.9 SOCKET HEAD CAP SCREWS) TO THE UNLOADED STRUCTURE, THE ADHESIVE APPLIED, THE SENSORS THEN AGAIN LOOSELY BOLTED AT ALL FIXATION POINTS. THEN TIGHTEN ALTERNATIVELY IN THREE STAGES TO ACHIEVE AND EVEN TORQUE FOR EACH OF THE MOUNTING BOLTS. TYPICALLY 10Nm, 20Nm TO ACHIEVE 30Nm.

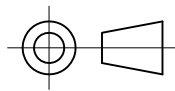
	TC PROCESS EQUIPMENT COPYRIGHT THRIVE CONSULTING PTY. LTD, SYDNEY AUSTRALIA. NO PART OF THIS DRAWING MAYBE REPRODUCED WITHOUT PERMISSION		TITLE DUAL AXIS (3 HOLE) BOLT-ON STRAIN GAUGE	
	DRAWN    RHS    22.05.07 CHECKED   RAS    22.05.07 ENG. MGR. APPR'D    MAA    22.05.07		DRG No. PS0005502	SCALE 1:1

A3